

TECHNICAL DATA

Fluke 3540 FC Three-Phase Power Monitor



The 3540 FC Three-Phase Power Monitor is a portable, semi-fixed device that monitors electrical systems. When connected to Wi-Fi, the 3540 FC wirelessly transmits electrical measurements to the Fluke Connect™ cloud. Measurement data is available on any connected device using the Fluke Connect mobile app or web-based instance.

Monitoring an asset's electrical parameters—such as current and distortion—can reveal how the machinery or equipment is performing. Maintenance teams can view asset status without needing to be at assets or in dangerous areas.

Graphs are available to show trends and fluctuations of measurements during the monitoring period. Alarm settings notify users immediately when measurement values are outside specified thresholds.

Connecting the Fluke 3540 FC with Fluke Connect Condition Monitoring (FCCM) software allows teams to access asset data from anywhere. View real-time or historical measurements from a smart device, such as mobile phone, tablet, or PC/Mac computer.

Having immediate access to machinery performance information can be the deciding factor between downtime and preventing a stop in production. Understanding changes in equipment performance triggers the need to investigate further, the alternative is unknowingly letting the machine run to fail.

For example:

- A baseline reading at a critical pump is trending dangerously close to the maximum current rating, taking service factor into account.
- The total power at an induction furnace appears to be fluctuating abnormally during a curing cycle.
- Determining how often a submersible or hydraulic pump is cycling on/off to maintain flow or pressures, in some cases simply validating there is power to the pump.

Measurements:

- Single, split, and three phase loads
- Voltage, current, and frequency
- Power, including Active Power (VA), Non-Active Power (VAR), and Power Factor (PF)
- Total Harmonic Distortion (%)



SAFETY FIRST

Deploying cloud-connected power monitors limits worker interaction to difficult-to-reach or dangerous areas

SHAREABLE DATA

Keep everyone on the same page by sharing data with teams, experts, or executives

MORE THAN JUST A LOGGER

Powered from the measurement circuit, configuration checker can automatically correct connection errors

ALWAYS ON

The Monitor includes a mode to log measurements when no connection to Fluke Connect Cloud is available

Specifications

Electrical specifications	
Single and Three Phase Topologies	
Wiring configurations	1- Φ , 1- Φ IT, Split phase, 3- Φ wye, 3- Φ wye IT, 3- Φ wye balanced, 3- Φ delta, 3- Φ Aron/Blondel (2-element delta), 3- Φ delta open leg, 3- Φ high leg delta, 3- Φ delta balanced. Currents only (load studies)
Voltage inputs	
Number of inputs	4 (3 phases and neutral)
Maximum input voltage	1,000 Vrms (1,700 Vpk) phase to neutral
Bandwidth	42.5 Hz to 3.5 kHz
Scaling	1:1, variable
Current inputs	
Number of inputs	3, mode selected automatically for attached sensor
Bandwidth (-3 dB)	42.5 Hz to 3.5 kHz
Measurement Hardware Sampling	
Resolution	16-bit synchronous sampling
Sampling frequency	10.24 kHz at 50/60 Hz, synchronized to mains frequency
Input signal frequency	Mains 50/60 Hz (42.5 to 69 Hz)
Data storage	Internal flash memory (not user replaceable)
Memory size	Typical 1 offline logging session of 1 week with 1 second intervals. The number of possible logging sessions and logging period depends on user requirements.
Measured parameters	Voltage, current, frequency, THD V, THD A, power, power factor, fundamental power, DPF
Averaging interval	1 s
Total harmonic distortion	THD for voltage and current is calculated on 25 harmonics
Interfaces	
USB-A	Firmware updates, max. supply current: 120 mA
WiFi	
Supported modes	Direct connection and connection to infrastructure
Security	WPA2-AES with pre-shared key
Power supply	
Voltage range	nominal 100 V to 500 V (85 V min to 550 V max) using safety plug input
Mains power	nominal 100 V to 240 V (85 V min to 265 V max) using IEC 60320 C7 input
Power consumption	Maximum 50 VA (max. 15 VA when powered using IEC 60320 input)
Standby power	<0.3 W only when powered using IEC 60320 input
Efficiency	$\geq 68.2\%$ (in accordance with energy efficiency regulations)
Mains frequency	50/60 Hz $\pm 15\%$
Battery power	Li-ion 3.7 V, 9.25 Wh, customer-replaceable
On-battery runtime	Up to 4 hr (up to 5.5 hr in energy saving mode)
Charging time	<6 hr
Power Source	wall outlet and measurement input line

Accuracy at reference conditions

Parameter	Range	Accuracy		
		Max. resolution	Intrinsic accuracy at reference conditions (% of reading + % of range)	
Voltage	1,000 V	0.1 V	± (0.2 % + 0.01 %)	
Current				
Direct input	Rogowski Mode	15 mV	0.01 mV	± (0.3 % + 0.02 %)
		150 mV	0.1 mV	± (0.3 % + 0.02 %)
	Clamp Mode	50 mV	0.01 mV	± (0.2 % + 0.02 %)
		500 mV	0.1 mV	± (0.2 % + 0.02 %)
1500 A iFlex	150 A	0.01 A	± (1 % + 0.02 %)	
	1,500 A	0.1 A	± (1 % + 0.02 %)	
3000 A iFlex	300 A	1 A	± (1.5 % + 0.03 %)	
	3,000 A	10 A	± (1 % + 0.02 %)	
6000 A iFlex	600 A	1 A	± (1.5 % + 0.03 %)	
	6,000 A	10 A	± (1.5 % + 0.03 %)	
i40s-EL 40 A	4 A	1 mA	± (0.7 % + 0.02 %)	
	40 A	10 mA	± (0.7 % + 0.02 %)	
Frequency	42.5 Hz to 69 Hz	0.01 Hz	± (0.1 %)	
Voltage min/max	1,000 V	0.1 V	± (1 % + 0.1 %)	
Current min/max	defined by accessory	defined by accessory	± (5 % + 0.2 %)	
THD on voltage	1,000 %	0.1 %	± (2.5 % ± 0.05 %)	
THD on current	1,000 %	0.1 %	± (2.5 % ± 0.05 %)	

Power/Energy

Parameter	Direct input ¹	iFlex1500-12	iFlex3000-24	iFlex6000-36	i40s-EL
Parameter	Clamp: 50 mV/500 mV	150 A/1,500 A	300 A/3,000 A	600 A/6,000 A	4 A/40 A
	Rogowski: 15 mV/150 mV				
Power range W, VA, var	Clamp: 50 W/500 W	150 kW/1.5 MW	300 kW/3 MW	600 kW/6 MW	4 kW/40 kW
	Rogowski: 15 W/150 W				
Max. resolution W, VA, var	0.1 W	0.01 kW/0.10 kW	1 kW/10 kW	1 kW/10 kW	1 W/10 W
Max. resolution PF, DPfund.	0.01				
	2.5 % of measured apparent power				
Phase (voltage to current) of range ¹	± 0.2°	± 0.28°			± 1°

¹ Only for calibration laboratories

iFlex probe specifications

Measuring range	
iFlex 1500-12	1 A ac to 150 A ac / 10 A ac to 1500 A ac
iFlex 3000-24	3 A ac to 300 A ac / 30 A ac to 3000 A ac
iFlex 6000-36	6 A ac to 600 A ac / 60 A ac to 6000 A ac
Nondestructive current	100 kA (50/60 Hz)
Intrinsic error at reference condition ¹	± 0.7 % of reading
Accuracy 3540 FC + iFlex	
iFlex 1500-12 and iFlex 3000-24	± (1 % of reading + 0.02 % of range)
iFlex 6000-36	± (1.5 % of reading + 0.03 % of range)
Temperature coefficient over operating temperature range	
iFlex 1500-12 and iFlex 3000-24	0.05 % of reading / °C (0.09 % of reading / °F)
iFlex 6000-36	0.1 % of reading / °C (0.18 % of reading / °F)

Positioning error with position of conductor in the probe window

	iFlex 1500-12, iFlex 3000-24	iFlex 6000-36
Probe Window A	± (1 % of reading + 0.02 % of range)	± (1.5 % of reading + 0.03 % of range)
Probe Window B	± (1.5 % of reading + 0.02 % of range)	± (2.0 % of reading + 0.03 % of range)
Probe Window C	± (2.5 % of reading + 0.02 % of range)	± (4 % of reading + 0.03 % of range)

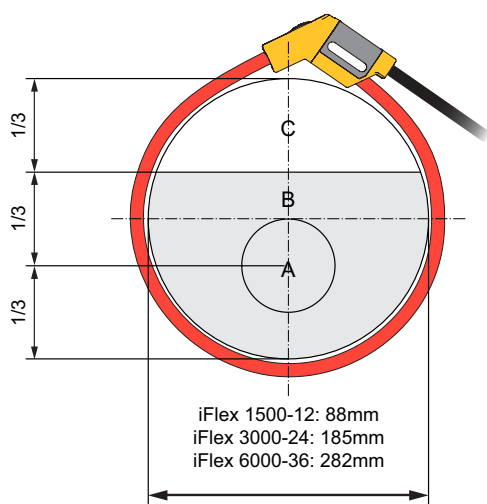

Figure. iFlex Probe Window

iFlex probe specifications

External magnetic field rejection in reference to external current (with cable >100 mm from the head-coupling and r-coil)	40 dB
Phase shift	< ± 0.5°

Transducer length

iFlex 1500-12	305 mm (12 in)
iFlex 3000-24	610 mm (24 in)
iFlex 6000-36	915 mm (36 in)
Transducer cable diameter	7.5 mm (0.3 in)
Minimum bending radius	38 mm (1.5 in)

Output cable length

iFlex 1500-12	2 m (6.6 ft)
iFlex 3000-24 and iFlex 6000-36	3 m (9.8 ft)

Weight

iFlex 1500-12	115 g (4 oz)
iFlex 3000-24	170 g (6 oz)
iFlex 6000-36	190 g (7 oz)

Material

Transducer cable	TPR
Coupling	POM + ABS/PC
Output cable	TPR/PVC
Operating temperature	-20 °C to +70 °C (-4 °F to 158 °F) temperature of conductor under test shall not exceed 80 °C (176 °F)
Storage temperature	-40 °C to +80 °C (-40 °F to 176 °F)
Operating relative humidity	15% to 85% noncondensing
IP rating	IEC 60529:IP50
Operating altitude	2,000 m (6,500 ft) up to 4,000 m (13,000 ft) derate to 1,000 V CAT II / 600 V CAT III / 300 V CAT IV
Storage altitude	12 km (40,000 ft)
Warranty	1 year

Bandwidth	10 Hz to 23.5 kHz (probe only)
Frequency derating	I x f ≤ 385 kA Hz
Working voltage	1,000 V CAT III, 600 V CAT IV

¹Reference condition:

- Environmental: 23 °C ±5 °C, no external electrical/magnetic field, RH 65 %
- Primary conductor in center position

General specifications		
Color LCD display	4.3-inch active matrix color TFT, 480 pixels x 272 pixels, resistive touch panel	
Warranty	3540 FC and built-in power supply	2 years (battery not included)
	Accessories	1 year
Calibration cycle	2 years	
Dimensions (wxhxd)	3540 FC	19.8 cm x 16.7 cm x 5.5 cm (7.8 in x 6.6 in x 2.2 in)
	Detachable power supply	13.0 cm x 13.0 cm x 4.5 cm (5.1 in x 5.1 in x 1.8 in)
	3540 FC with power supply attached	19.8 cm x 16.7 cm x 9 cm (7.8 in x 6.6 in x 4.0 in)
Weight	3540 FC	1.1kg (2.5 lb)
	Power Supply	400 g (0.9 lb)
Tamper protection	Kensington lock	

Environmental specifications	
Operating temperature	0 °C to 45 °C (32 °F to 113 °F)
Storage temperature	<20 °C to +60 °C (-4 °C to +140 °F), with battery: -20 °C to +50 °C (-4 °F to +122 °F)
Operating humidity	<10 °C (<50 °F) non condensing
	10 °C to 30 °C (50 °F to 86 °F) ≤95 %
	30 °C to 40 °C (86 °F to 104 °F) ≤75 %
	40 °C to 45 °C (104 °F to 113 °F) ≤45 %
Operating altitude	2000 m (6,500 ft) (up to 4,000 m derate to 1,000 V CAT II/600 V CAT III/300 V CAT IV)
Storage altitude	12,000 m (39,000 ft)
IP rating	IEC 60529:IP50, in connected condition with protection caps in place
Vibration	MIL-T-28800E, Type 3, Class III, Style B

Safety		
IEC 61010-1	IEC mains input	Overvoltage Category II, Pollution Degree 2
	Voltage terminals	Overvoltage Category IV, Pollution Degree 2
IEC 61010-2-033	CAT IV 600 V/CAT III 1,000 V	

Electromagnetic compatibility (EMC)	
International	IEC 61326-1: Industrial
Korea (KCC)	Class A Equipment (Industrial Broadcasting & Communication Equipment)
USA (FCC)	47 CFR 15 subpart B. This product is considered an exempt device per clause 15.103.

Wireless radio with adapter	
Frequency range	2,412 MHz to 2,462 MHz
Output power	<100 mW



Preventive maintenance simplified. Rework eliminated.

Save time and improve the reliability of your maintenance data by wirelessly syncing measurements using the Fluke Connect® system.

- Eliminate data-entry errors by saving measurements directly from the tool and associating them with the work order, report, or asset record.
- Maximize uptime and make confident maintenance decisions with data you can trust and trace.
- Access baseline, historical, and current measurements by asset.
- Move away from clipboards, notebooks, and multiple spreadsheets with a wireless, one-step measurement transfer.
- Share your measurement data using ShareLive™ video calls and emails.
- The 3540 FC is part of a growing system of connected test tools and equipment maintenance software. Visit the website to learn more about the Fluke Connect® system.

Find out more at www.fluke.com



All trademarks are the property of their respective owners. Wi-fi or cellular service required to share data. Smartphone, wireless service and data plan not included with purchase. First 5 GB of storage is free.

Smart phone wireless service and data plan not included with purchase. Fluke Connect is not available in all countries.

Ordering information

FLUKE-3540 FC Three-Phase Power Monitor

Included

Instrument, power supply, voltage test leads, dolphin clips (4x), 1,500A flexible current probe (3x), magnetic hanging kit, wi-fi to USB adapter, and color coding set



Accelix. Connected Reliability.

PRÜFTECHNIK Condition Monitoring GmbH

Oskar-Messter-Str. 19-21
85737 Ismaning
Germany
T + 49 8999616 420
salessupport@pruftechnik.com

©2019 Fluke Corporation. 4/2019 6008088h-en

Modification of this document is not permitted without written permission from Fluke Corporation.